



Generator set
Sound-proof type
QSV440CS-AU

SPECIFICATIONS



1 Standards & Conditions

Design Standards

The designs and the productions are in conformity with:

- Conformance Européenne (CE)
- ISO8528-5:2005
- AS 3000-2018
- AS 3010-2017

Environmental Operating Conditions

- Installation place: Outdoors or indoors (well ventilated).
- Ambient temperature: -25°C to 50°C. The coolant heater is needed when the temperature is below 5°C
- Humidity: Less than 90%.
- Altitude: Below one thousand (1000) meters above sea level.

Factory Inspection

- Inspection items.
- Protection devices working test.
- Starting ability in normal temperature.
- 50% rated power load moment capability.
- Voltage deviation and speed variation: 0%, 25%, 50%, 75%, 100%, 110% Load.

Painting Process

- Painting process specifications and colors are based on the manufacturer's standard.
- The customer could also choose the color which the manufacturer offers.

2 General Features

- Cummins engine QSZ13-G2
- Close coupled to Stamford alternator S4L1D-G4
- Microprocessor control module PLC-920
- Schneider main circuit breaker: 630A
- Rotate speed governor: Electrical governor
- Excitation system: Self excited,SHUNT
- A.V.R model: AS440
- Key switch
- Emergency stop switch
- ATS(automatic transfer switch)receptacle

- Remote run connector
- 2x12V/120AH sealed for life maintenance free battery
- Lockable battery isolator switch
- Powder coated canopy
- 45°C radiator
- Steel base frame
- Vibration isolators between the engine/alternator and base frame
- Dry type air filter
- Base fuel tank for 11 hours running
- Drain points for fuel tank
- Operation Manual / Specifications

3 Equipment

General technical data

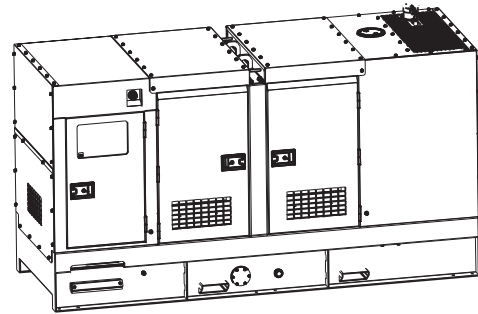

Model.....	QSV440CS-AU
Fuel tank.....	1000L
Dry weight.....	4650kg
Sound pressure level @ 7m.....	74.0dBA
Dimensions L×W×H.....	3950x1300x1980mm
Standby Power.....	468kVA/375kW
Prime Power.....	438kVA/350kW

Voltage	380V	400V	415V		
Ampere	665.5A	632.2A	609.4A		
Genset Fuel Consumption					
Frequency/Load	25%	50%	75%	100%	110%
50Hz (L/h)	23.6	44.2	65.6	88.8	98.7

Dck Yf ' GrghYa

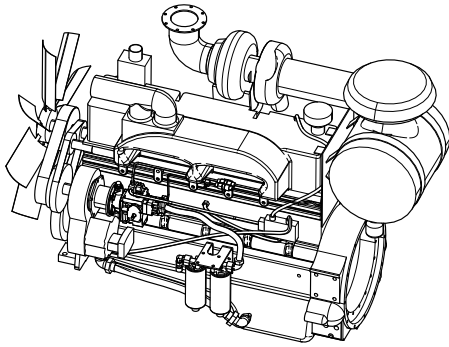

Engine Manufacturer/Brand	Cummins
Engine Model	QSZ13-G2
Dimensions L×W×H.....	1396×1049×1232mm
Dry Weigh (approx.)	1245kg
Number of Cylinders.....	6
Bore.....	130mm
Stroke	163mm
Displacement.....	13L
Compression Ratio	17
Type of injection.....	Direct injection
Intake System.....	Turbocharged, air-to-air charged cooled
Intake Resistance	≤6.2KPa
Cooling System	Water cooled
Fan	Pusher
Battery Voltage	24V
Type of Fuel.....	No.2 or ASTM D975
Type of Oil	Class CH-4 oil as per API classification
Oil Capacity	45.4L
Type of Coolant	Glycol mixture
Coolant Capacity	23.1L
Back Pressure	≤13KPa
Standby Power589kW
Prime Power536kW

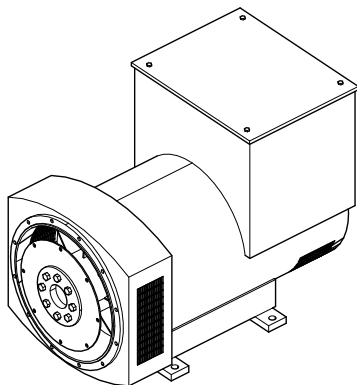

Alternator Manufacturer/Brand	Stamford
Alternator Model	S4L1D-G4
Exciter.....	Brushless
Cooling Fan	Cast alloy aluminum
Windings.....	100% copper
Insulation Class	H
Winding Pitch.....	.2/3
Terminals	12
Drip Proof	IP23
Altitude.....	≤1000m
Overspeed	2250rpm
Air Flow.....	N/A
Voltage Regulation	±1.0%
Total Harmonic TGH / THCat no load < 1.5 % - on load < 5%	
Telephone Interference.....	THF<2%;TIF<50

PLC-920 Control System

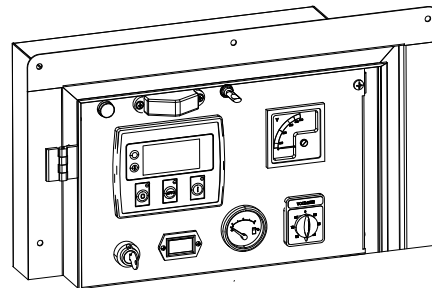

PLC-920 is an advanced control module based on microprocessor designed to control the engine via push buttons on the front panel. The module is used to start and stop the engine and indicate fault conditions, automatically shutting down the engine and giving a true first up fault condition of an engine failure.

Standard Control Function

- Manual Engine Control Module
- Low Oil Pressure
- High Engine Temperature
- Auxiliary Shutdown
- Overspeed Protection
- Protection hold-off timer
- Charge Failure warning

4 Overall Dimensions

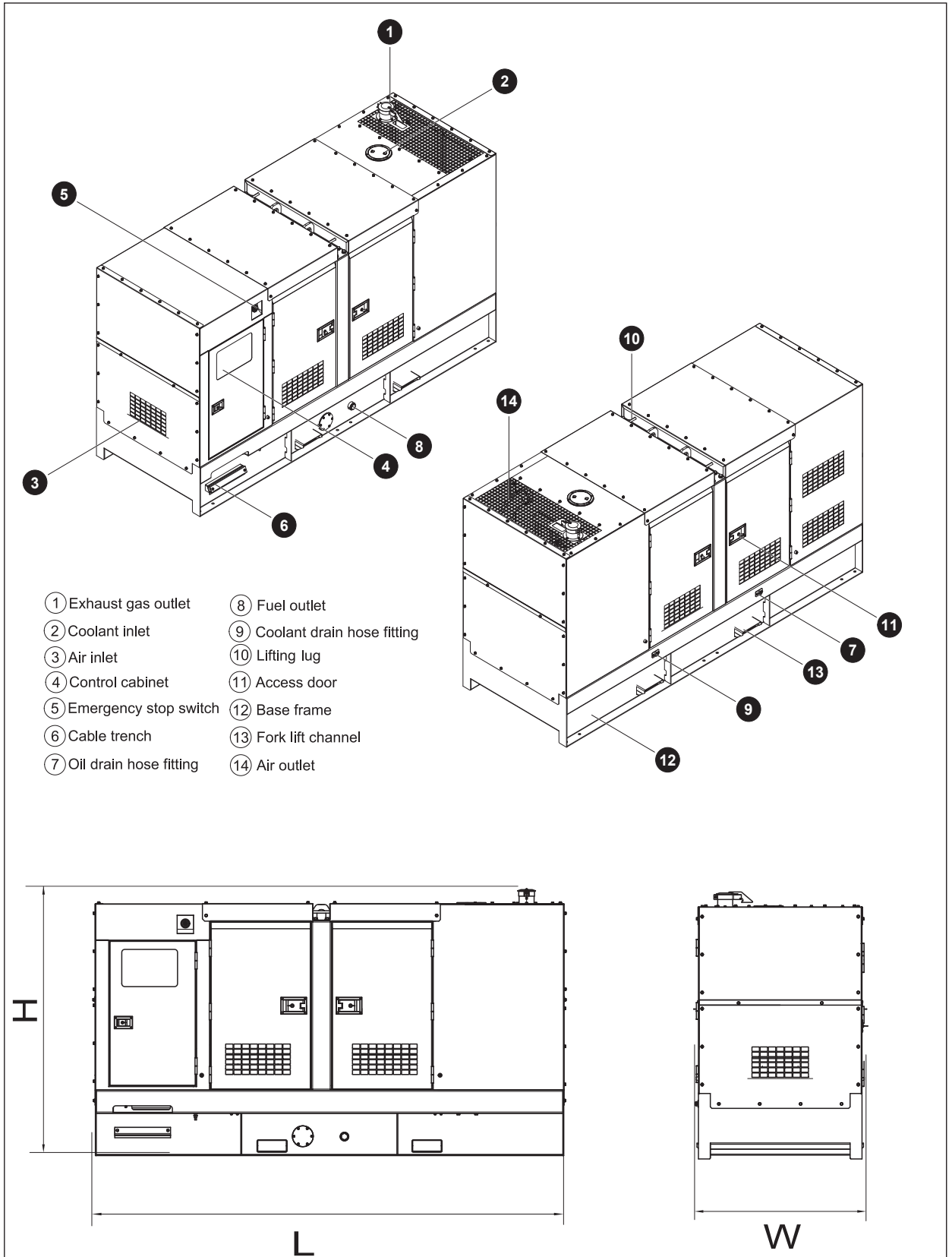

5 Control System

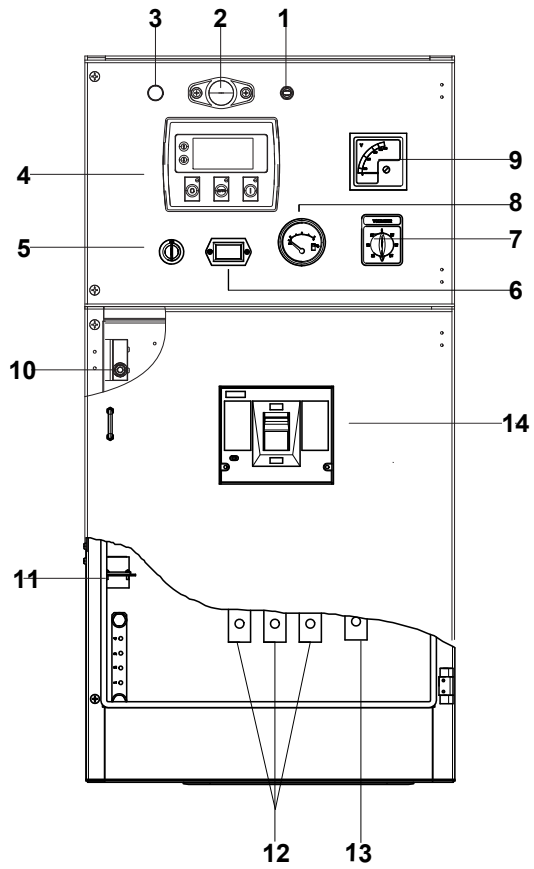

Control & field wiring cabinet

Ref.	Description
1	Control cabinet lamp switch
2	Control cabinet lamp
3	Charge indicator
4	Control module
5	Key switch
6	Time counter
7	Voltage changer-over switch
8	Fuel level meter
9	Voltage meter
10	Limit switch
11	Mains input/Remote control/ATS connector
12	Live wire terminal
13	Neutral wire terminal
14	Main circuit breaker

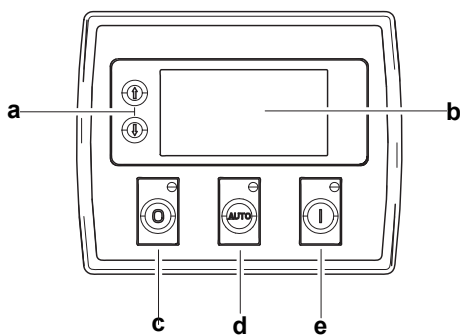

Control module

Ref.	Description
a	Navigation button«» Accept (Configuration mode only)
b	Main status display
c	Stop/reset button«» Next page (Configuration mode only)
d	Auto start button«» Decrease value/next item (Configuration mode only)
e	Start button«» Increase value/next item (Configuration mode only)

1000033834-A2-E

10.2020

<http://www.powerlinkworld.com>

*Specification may change without prior notice. For more info.,
contact Power Link or your local distributors please.*