

**Generator set**  
**Sound-proof type**  
**GMS10KS-AU**

# **SPECIFICATIONS**

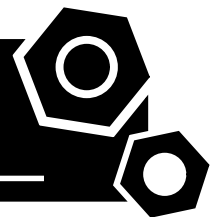

## 1 Standards & Conditions

### Design Standards

The designs and the productions are in conformity with:

- Conformance Européenne (CE)
- ISO8528-5:2005
- GB/T2820.5-2009
- AS 3000-2018
- AS 3010-2017

### Environmental Operating Conditions

- Installation place: Outdoors or indoors (well ventilated).
- Ambient temperature: -25°C to 50°C. The coolant heater is needed when the temperature is below 5°C
- Humidity: Less than 90%.
- Altitude: Below one thousand (1000) meters above sea level.

### Factory Inspection

- Inspection items.
- Protection devices working test.
- Starting ability in normal temperature.
- 50% rated power load moment capability.
- Voltage deviation and speed variation: 0%, 25%, 50%, 75%, 100%, 110% Load.

### Painting Process

- Painting process specifications and colors are based on the manufacturer's standard.
- The customer could also choose the color which the manufacturer offers.

## 2 General Features

- Kubota engine D1105-BG
- Close coupled to LSA alternator LSA40VS1
- Microprocessor control module PLC-920
- SCHNEIDER main circuit breaker: 16A
- Rotate speed governor: Mechanical governor
- Excitation System: Self excited
- A.V.R
- Key switch
- Emergency stop switch
- ATS (automatic transfer switch) receptacle
- Convenience receptacles: 3P and 1P

- 1x12V/72AH sealed for life maintenance free battery
- Lockable battery isolator switch
- Powder coated canopy
- 50°C radiator
- Oil pump on the engine
- Steel base frame with forklifts
- Vibration isolators between the engine/alternator and base frame
- Dry type air filter
- Base fuel tank for 28 hours running
- Drain points for fuel tank
- Operation Manual / Specifications

## 3 Equipment Specification

### General technical data

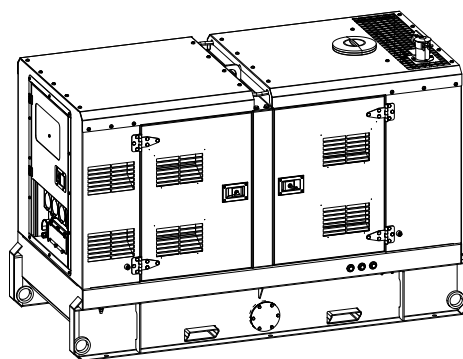

Model.....GMS10KS-AU  
 Structure type .....RS  
 Tank capacity.....100L  
 Dry weigh.....700kg  
 Noise level @7m ..... 64.7dBA  
 Dimensions L×W×H..... 1932x927x1308mm  
 Standby Power ..... 11kVA/8.8kW  
 Prime Power..... 10kVA/8kW

Voltage	380V	400V	415V	440V	
Ampere	15.2A	14.4A	13.9A	13.1A	
Genset Fuel Consumption					
Frequency/Load	25%	50%	75%	100%	110%
50Hz (L/h)	N/A	1.8	2.9	3.5	3.9

## Diesel engine

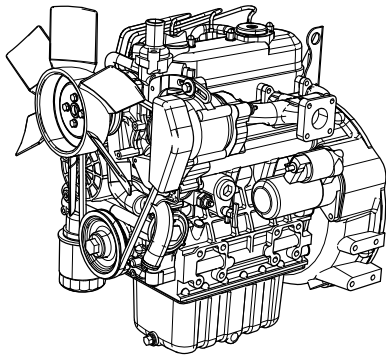

Engine Manufacturer/Brand.....	KUBOTA
Engine Model.....	D1105-BG
Dimensions L×W×H.....	549.3×398.0×604.7mm
Dry Weigh (approx.) .....	93kg
Number of Cylinders.....	3
Bore.....	78mm
Stroke .....	78.4mm
Displacement.....	1.123L
Compression Ratio.....	22
Type of Injection .....	Direct injection
Intake System.....	Natural aspirated
Intake Resistance.....	1.96kPa
Cooling System .....	Water cooled
Fan .....	Pusher
Battery Voltage.....	12V
Type of Fuel.....	No.2-D(ASTM D975)
Type of Oil .....	Better than API CD class
Oil Capacity .....	5.1L
Type of Coolant .....	Glycol mixture
Coolant Capacity.....	6.4L
Back Pressure .....	≤7.07kPa
Standby Power.....	9.5kW
Prime Power .....	8.4kW
Fuel Consumption(100%load).....	3.5L/h

## Alternator

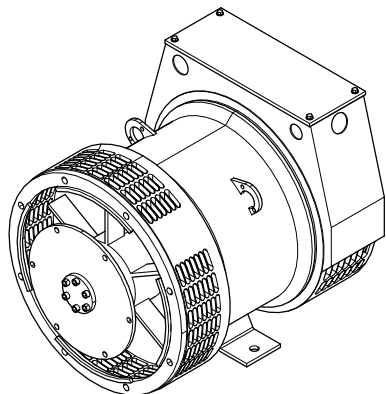

Alternator Manufacturer/Brand.....	Leroy Somer
Alternator Model .....	LSA40VS1
Exciter.....	Brushless
Cooling Fan .....	Synthetic plastic
Windings.....	100% copper
Insulation Class .....	H
Winding Pitch.....	2/3
Terminals .....	12
Drip Proof .....	IP23
Altitude.....	≤1000m
Overspeed .....	2250rpm
Air Flow.....	0.11 m³/s(50Hz),0.135m³/s(60Hz)
Voltage Regulation .....	±0.5 %
Total harmonic TGH / THCat no load < 1.5 % - on load < 5%	
Telephone Interference.....	THF<2%;TIF<50

## PLC-920 Control System

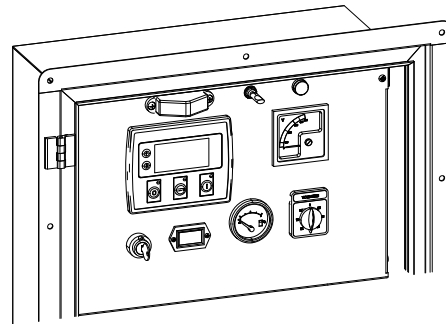

PLC-920 is an advanced control module based on microprocessor designed to control the engine via push buttons on the front panel. The module is used to start and stop the engine and indicate fault conditions, automatically shutting down the engine and giving a true first up fault condition of an engine failure.

### Standard Control Function

- Manual Engine Control Module
- Low Oil Pressure
- High Engine Temperature
- Auxiliary Shutdown
- Overspeed Protection
- Protection hold-off timer
- Charge Failure warning

## 4 Overall Dimensions

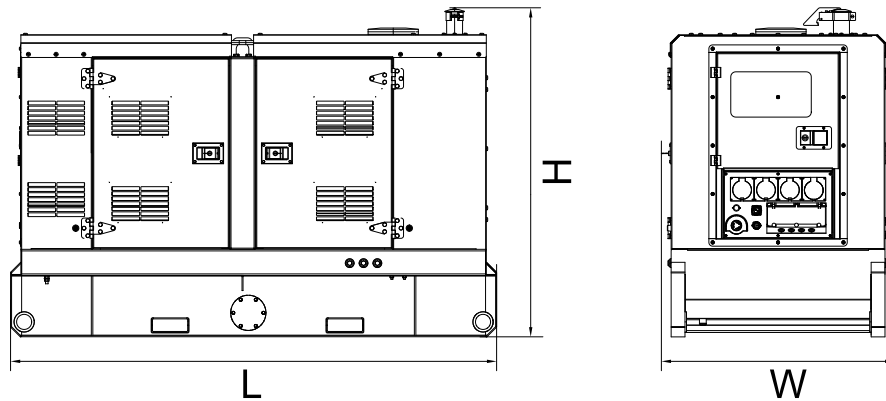
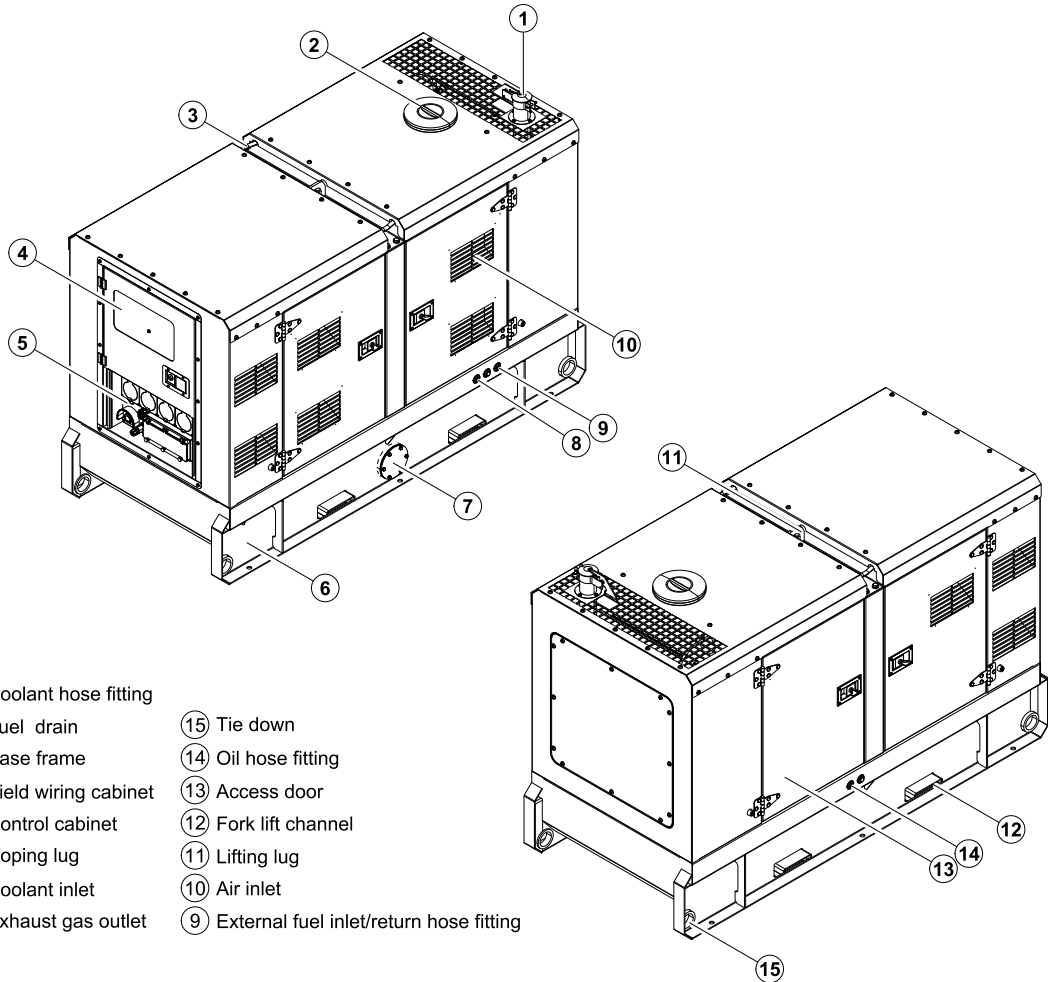

## 5 Control System

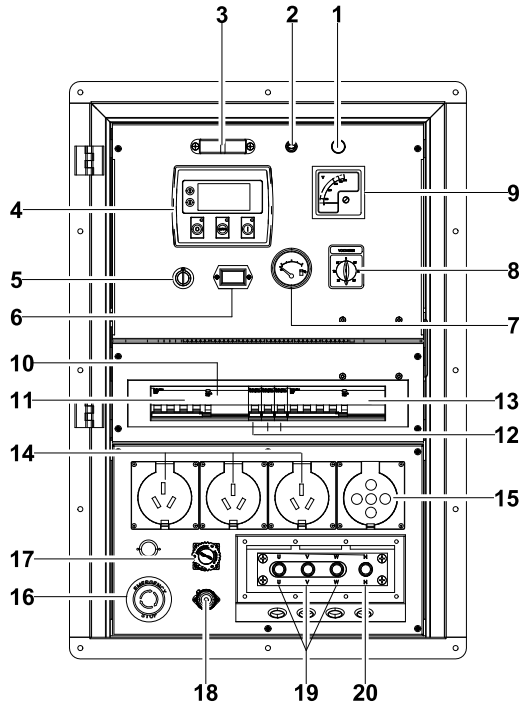

**Control & field wiring cabinet**

Ref.	Description
1	Charge indicator
2	Control cabinet lamp switch
3	Control cabinet lamp
4	Control module
5	Key switch
6	Time counter
7	Fuel level meter
8	Voltmeter change-over switch
9	Voltage meter
10	RCD.
11	Circuit breaker of three-phase convenience receptacle
12	Circuit breakers of single-phase convenience receptacle
13	Main circuit breaker
14	3x single-phase convenience receptacle
15	1x three-phase convenience receptacle
16	Emergency stop switch
17	Remote control/ ATS communication connector
18	Mains input/ Remote control communication connector
19	Live wire terminals
20	Neutral wire terminal

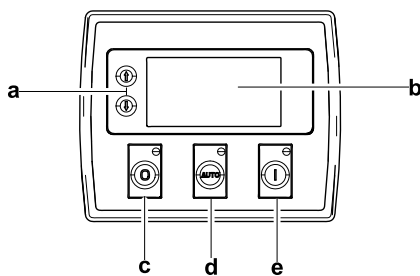

**Control module**

Ref.	Description
a	Navigation button; Accept (Configuration mode only)
b	Main status display
c	Stop/reset button; Next page (Configuration mode only)
d	Auto start button; Decrease value/next item (Configuration mode only)
e	Start button; Increase value/next item (Configuration mode only)

1000032175-A2-E
-----------------

03.2020
---------

<http://www.powerlinkworld.com>

*Specification may change without prior notice. For more info.,  
contact Power Link or your local distributors please.*