

Generator set
Sound-proof type
GMS130CS-AU

SPECIFICATIONS

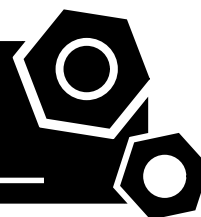

1 Standards & Conditions

Design Standards

The designs and the productions are in conformity with:

- Conformance Européenne (CE)
- ISO8528-5:2005
- GB/T2820.5-2009
- AS3000-2018
- AS3010.1-2017

Environmental Operating Conditions

- Installation place: Outdoors or indoors (well ventilated).
- Ambient temperature: -25°C to 50°C. The coolant heater is needed when the temperature is below 5°C
- Humidity: Less than 90%.
- Altitude: Below one thousand (1000) meters above sea level.

Factory Inspection

- Inspection items.
- Protection devices working test.
- Starting ability in normal temperature.
- 50% rated power load moment capability.
- Voltage deviation and speed variation: 0%, 25%, 50%, 75%, 100%, 110% Load.

Painting Process

- Painting process specifications and colors are based on the manufacturer's standard.
- The customer could also choose the color which the manufacturer offers.

2 General Features

- Cummins engine 6BTAA5.9-G2
- Close coupled to a Stamford alternator UCI274E
- Microprocessor control module PLC-7420
- ABB main circuit breaker: 200A
- Rotate speed governor: Electrical governor S6700E
- Excitation System: Self excited, Shunt
- A.V.R. Model: SX460
- Key switch
- Emergency stop switch
- ATS (automatic transfer switch) receptacle

- Remote run connector
- 2x12V/72AH sealed for life maintenance free battery
- Lockable battery isolator switch
- Powder coated canopy
- 50°C radiator
- Oil pump on the engine
- Non-returning valve for fuel inlet hose of the engine
- Steel base frame with forklifts
- Vibration isolators between the engine/alternator and base frame
- Dry type air filter
- Base fuel tank for 24 hours running
- Drain points for fuel tank
- Breather valve for fuel tank
- Operation's Manual / Specifications

3 Equipment Specification

General technical data

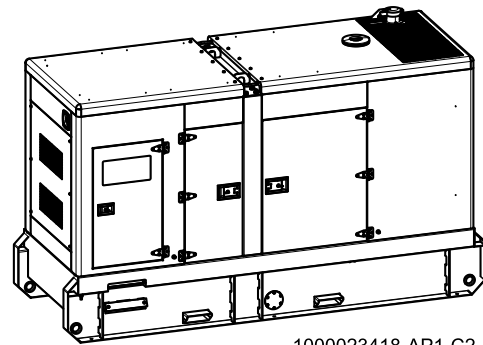

1000023418-AP1-C2

Model.....	GMS130CS-AU
Structure type	R
Tank capacity.....	620L
Dry weight.....	2259kg
Sound pressure level @7m	64.5dB(A)
Sound power level acc. 2000/14/EC	92.4dB(A)
Dimensions L×W×H.....	3312x1174x1974mm
Standby Power	143kVA/114kW
Prime Power	130kVA/104kW
Voltage/Ampere.....	415V/181A

Genset Fuel Consumption					
Frequency/Load	25%	50%	75%	100%	110%
50Hz (L/h)	9.0	16.0	23.0	30.0	34.0

Power System

1000067107-AP1-A17

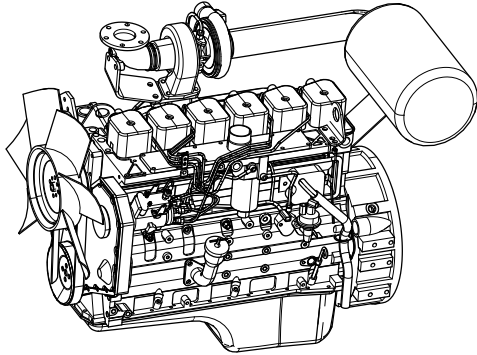

Engine Manufacturer/Brand	Cummins
Engine Model	6BTAA5.9G2
Dimensions L×W×H.....	1184.7*655.7*981.3
Dry Weigh (approx.)	411kg
Number of Cylinders	6
Bore	102mm
Stroke	120mm
Displacement.....	5.9L
Compression Ratio	16.8
Type of injection.....	Direct injection
Intake System.....	Turbocharged, air-to-air charge cooled
Intake Resistance	≤6.28kPa
Cooling System	Water cooled
Fan	Pusher
Battery Voltage	12/24V
Type of Fuel.....	Diesel
Type of Oil	15W40-CF4
Oil Capacity	14.2L
Type of Coolant	Glycol mixture
Coolant Capacity	34L
Back Pressure	≤10.1kPa
Standby Power	130kW
Prime Power	120kW
Fuel Consumption(100%load)	208g/kW.h

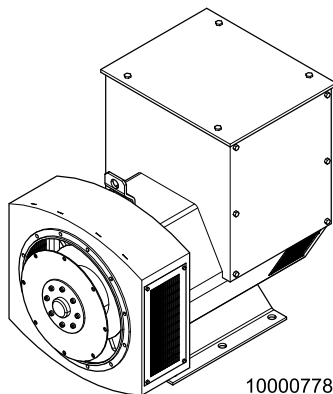

1000077845-AP1-A1

Alternator Manufacturer/Brand	Stamford
Alternator Model	UCI274E
Exciter.....	Brushless
Cooling Fan	Cast alloy aluminum
Windings.....	100% copper
Insulation Class	H
Winding Pitch.....	2/3
Terminals	12
Drip Proof	IP23
Altitude.....	≤1000m
Overspeed	2250 rpm
Air Flow.....	0.514m³/s(50HZ),0.617m³/s(60HZ)
Voltage Regulation	±1.0%
Total harmonic TGH / THCat no load < 1.5 % - on load < 5%	
Telephone Interference.....	THF<2%;TIF<50

PLC-7420 Control System

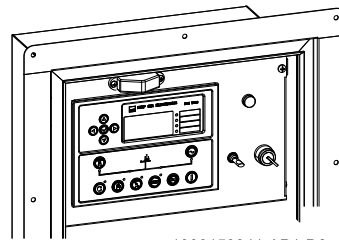

1000153341-AP1-D2

PLC-7420 is an advanced control module based on micro-processor, containing all necessary functions for protection of the genset and the breaker control. It can monitor the mains supply, and automatically start the engine when the mains is abnormal. Accurately measure various operational parameters and display all values and alarms information on the LCD. In addition, the control module can automatically shut down the engine and indicate the engine failure.

- Microprocessor control, with high stability and credibility
- Monitoring and measuring operational parameters of the mains supply and genset
- Indicating operation status, fault conditions, all parameters and alarms
- Multiple protections; multiple parameters display, like pressure, temp. etc.
- Manual, automatic and remote work mode selectable
- Real time clock for time and date display, overall runtime display, 250 log entries
- Overall power output display
- Integral speed/frequency detecting, telling status of start, rated operation, overspeed etc.
- Communication with PC via RS485 OR RS232 interface, using MODBUS protocol

4 Overall Dimensions

1000023418-DR1-C2

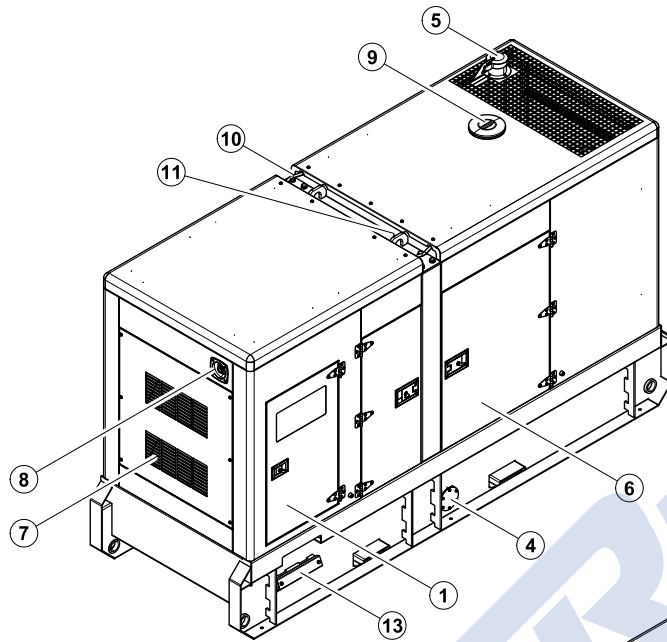

Dry weight	2259kg
Fuel tank capacity	620L
Dimensions L x W x H	3312x1174x1974mm

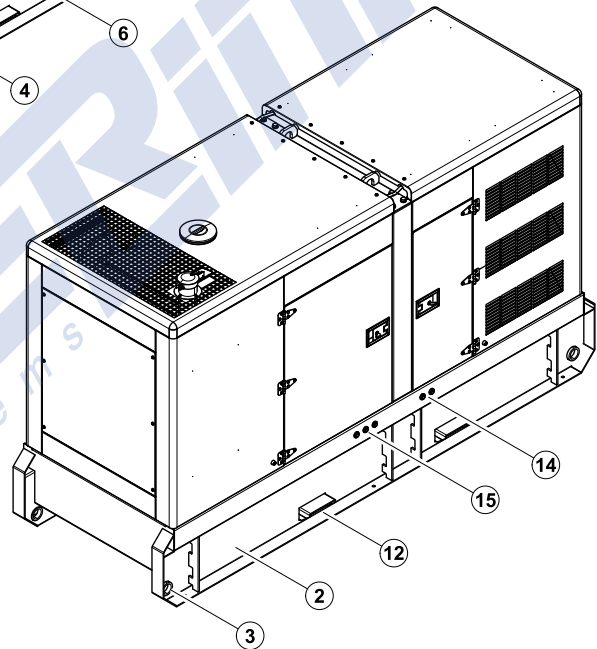

- ⑧ Emergency stop switch
- ⑦ Air inlet
- ⑥ Access door
- ⑤ Exhaust gas outlet
- ④ Fuel drain
- ③ Tie down
- ② Base frame
- ① Control cabinet
- ⑮ External fuel inlet/return hose fitting
- ⑭ Coolant/Oil drain hose fitting
- ⑬ Cable trench
- ⑫ Fork lift channel
- ⑪ Lifting lug
- ⑩ Roping lug
- ⑨ Coolant inlet

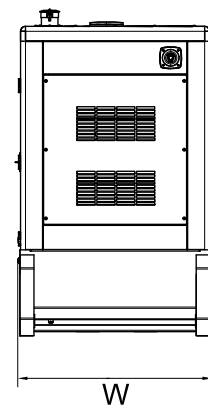
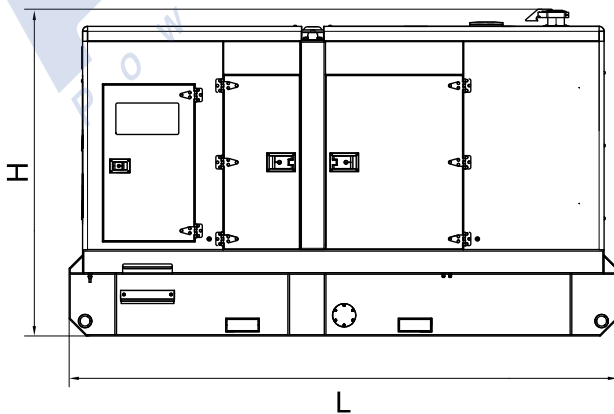

5 Control System

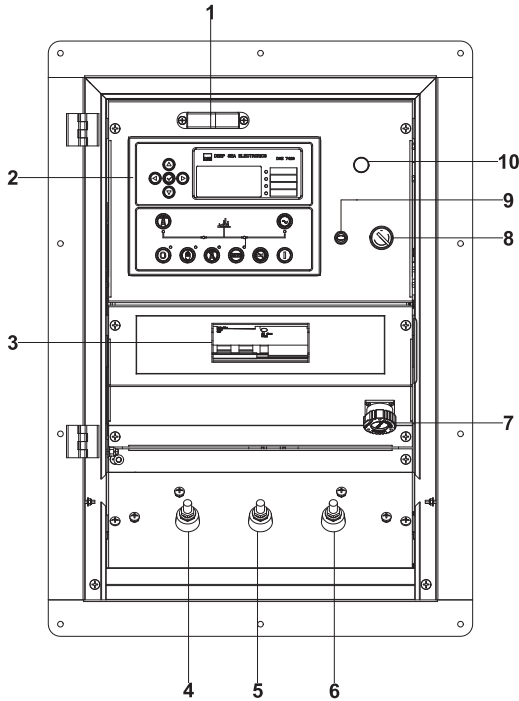

Control & Field wiring cabinet

Ref.	Description
1	Control cabinet lamp
2	Control module
3	Main circuit breaker
4	Live wire terminals
5	Neutral wire terminal
6	Ground wire terminal
7	Remote run connector
8	Key switch
9	Control cabinet lamp switch
10	Charge indicator

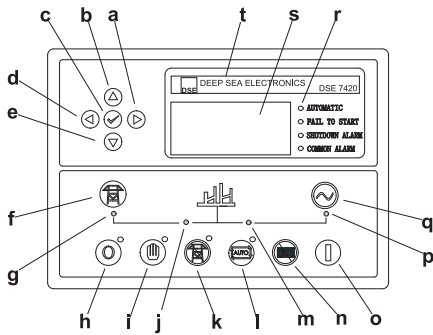

Control module

a	Button (next page)
b	Button (increase value / previous item)
c	Button (accept)
d	Button (previous page)
e	Button (decrease value / next item)
f	Button (transfer the load to the mains supply, when in Manual mode only)
g	Mains supply available LED
h	Stop / Reset button
i	Manual button (Manual control mode)
j	Mains supply on load LED
k	Test button (Test mode)
l	Auto button (Auto mode)
m	Genset on load LED
n	Mute/Lamp test button
o	Start button (Manual)
p	Genset available LED
q	Button (transfer the load to the genset, when in Manual mode only)
r	Alarm LED (4 alarm items)
s	LCD display
t	Control module name

1000023418-C2-E

06.2019

<http://www.powerlinkworld.com>

Specification may change without prior notice. For more info., contact Power Link or your local distributors please.